

## KÜHLZELLE24

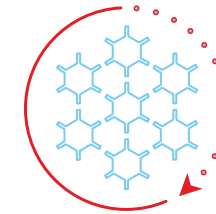

Weitere Informationen, Bilder, Anleitungen und Preise zu diesen Rivacold Kühl- und Tiefkühlaggregaten, sowie vielen weiteren Produkten finden Sie bei Ihrem Fachhändler Kühlzelle24.

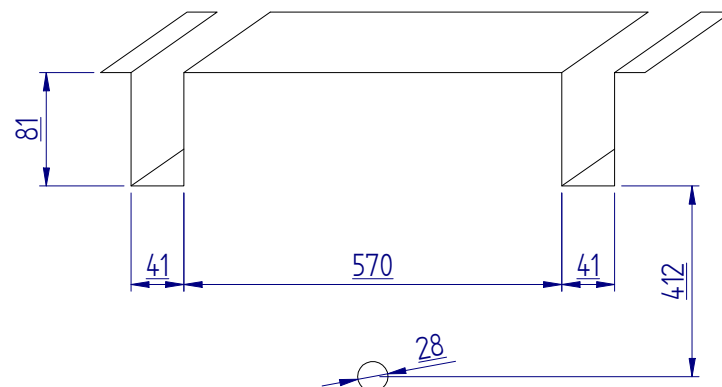
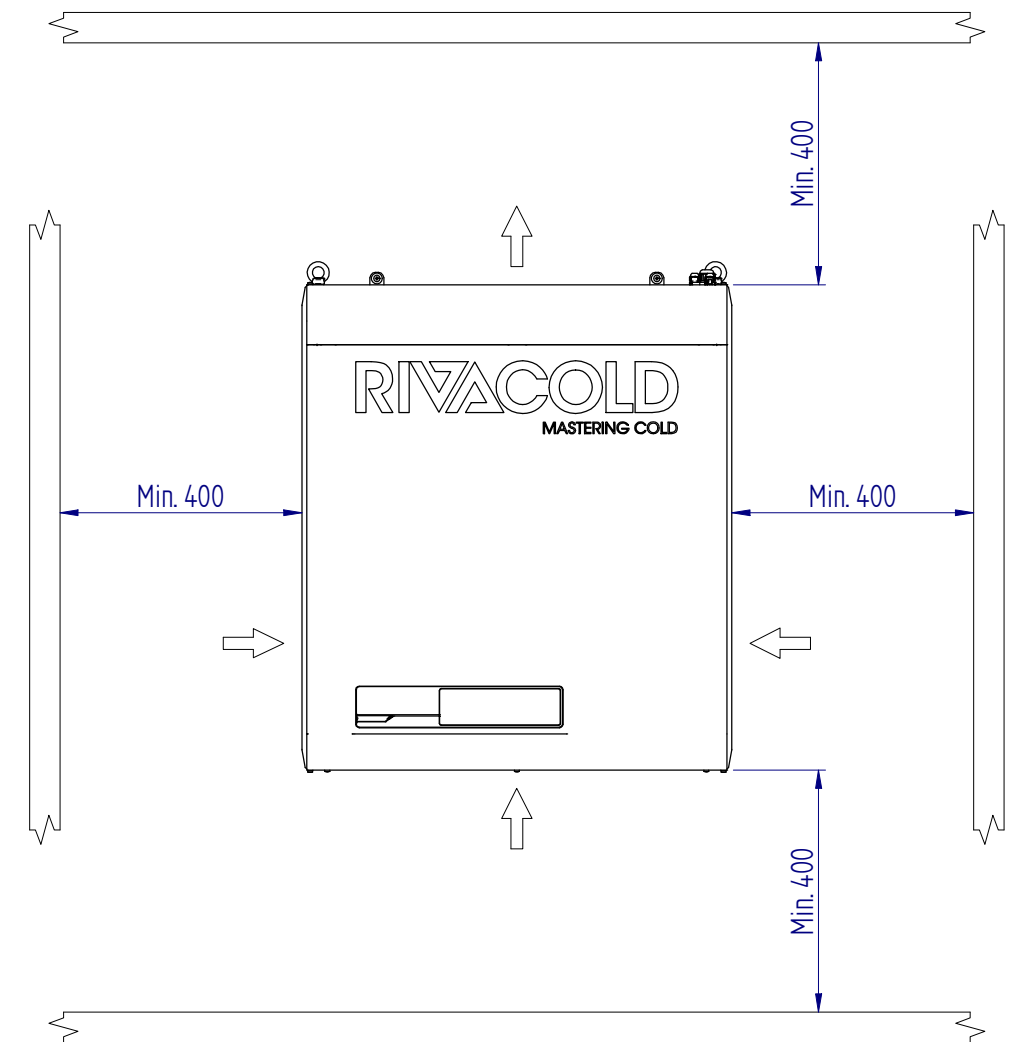

BEST SADDLE VERSION  
WS

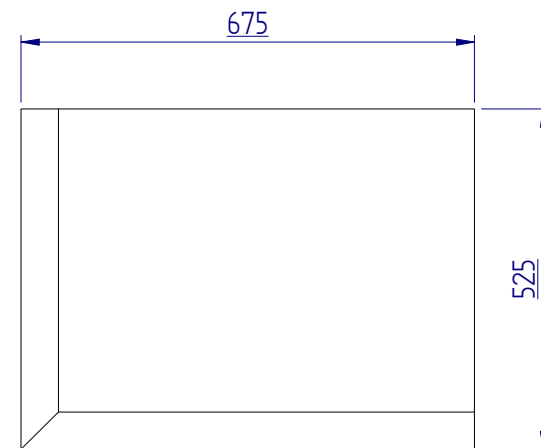

BEST PLUG-IN VERSION  
WT

MTE-015-00 10/02/2020 RIPRODUZIONE E/O DIFFUSIONE VIETATA COPY AND/OR DIFFUSION FORBIDDEN	00	14/10/2019					Polidori Gianmarco	Santilli G.	
	Rev.	Data / Date	Descrizione modifica / Modification description				Disegnatore	Approvato	
	Disegnatore / Designer			Approvato / Approved		Data / Date	Scala / Scale	Peso / Weight	Rif. Int.-Est. / Int.-Ext. Ref.
	Materiale / Material			Materia Prima / Raw Material		Tolleranze gen. / Gen. tolerances			
	Rivestimento superficiale / Surface coating			Cliente / Customer		Lamiere Sheet metal UNI ISO 2768-mK Tolleranze per lunghezze, angoli, forma e posizione / Tolerances for lengths, angles, shape and position			
Denominazione / Description						Foglio / Sheet	Tubazioni / Pipes Cavi / Cables		

BEST\_W35

2 di 6

RIVACOLD  
MASTERING COLD

A3

Codice Commerciale / Comm. Code

Codice / Code

BEST\_W35