

KÜHLZELLE24

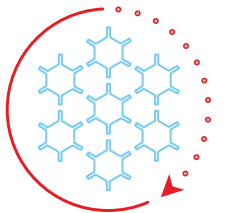

Weitere Informationen, Bilder, Anleitungen und Preise zu diesen Rivacold Kühl- und Tiefkühlaggregaten, sowie vielen weiteren Produkten finden Sie bei Ihrem Fachhändler Kühlzelle24.

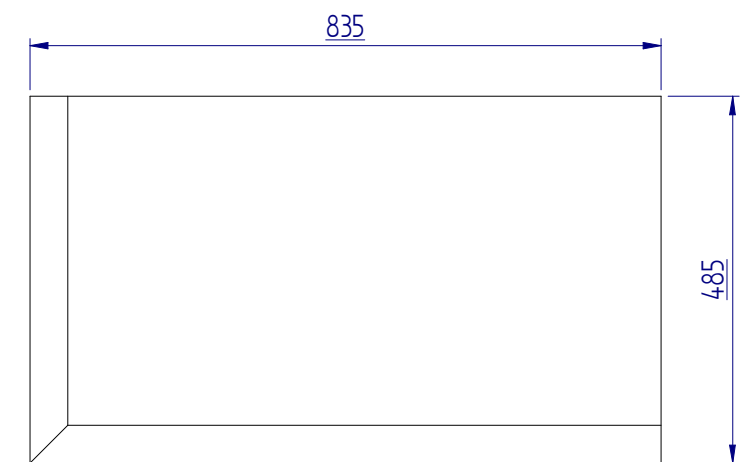
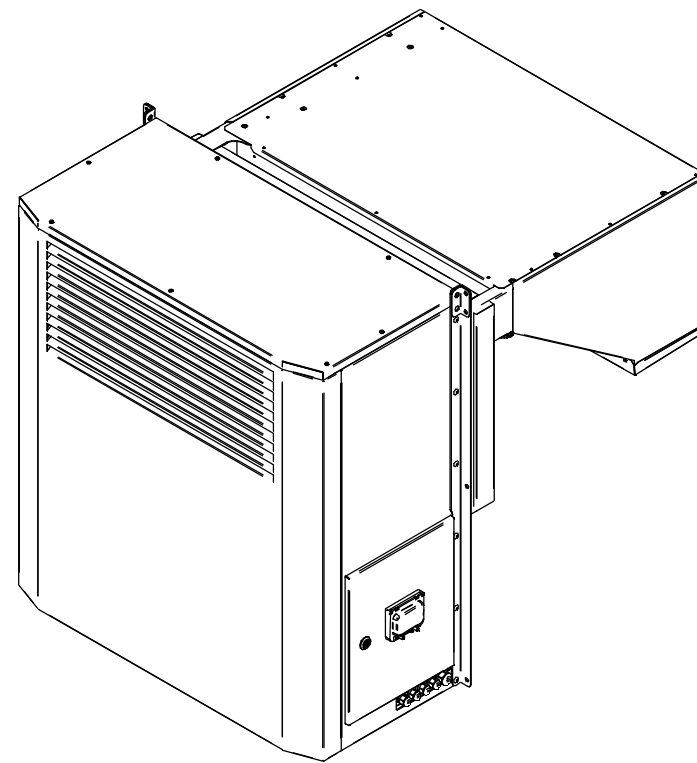
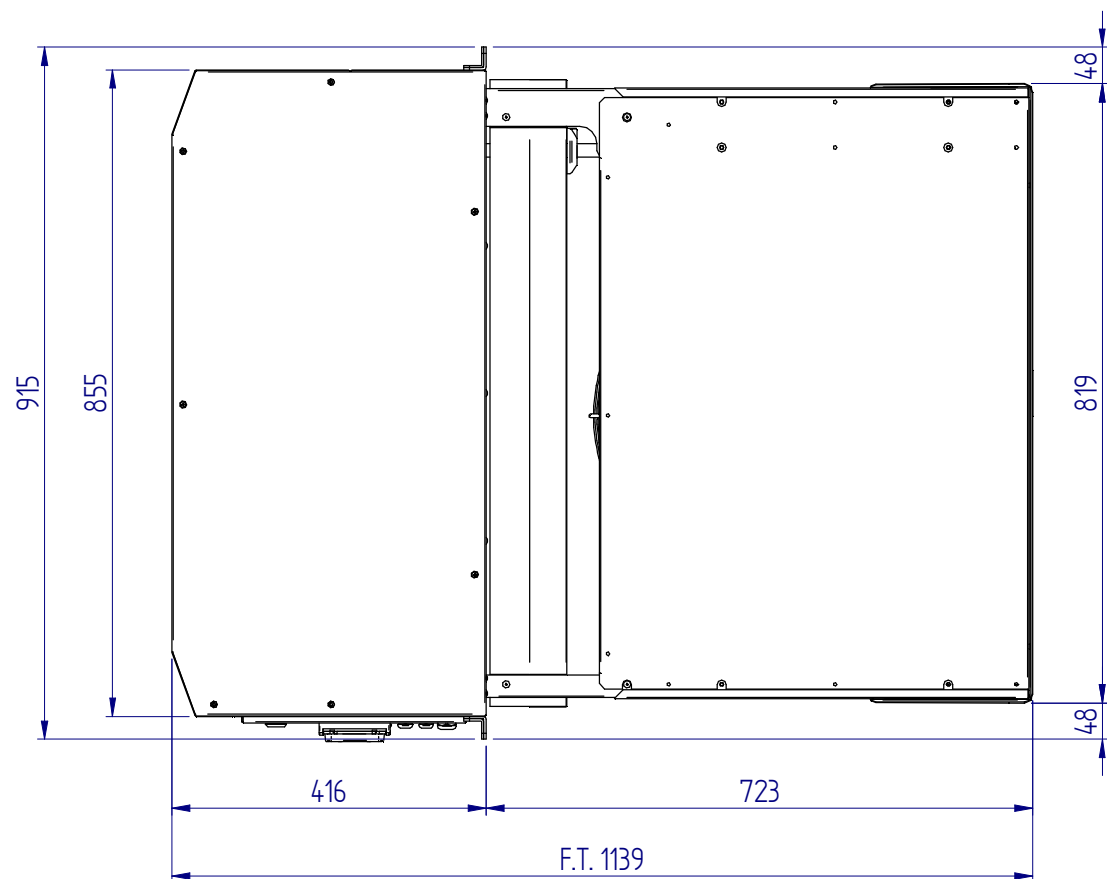

FORO PER TAMPONE

MTE-015-00 10/02/2020 RIPRODUZIONE E/O DIFFUSIONE VIETATA COPY AND/OR DIFFUSION FORBIDDEN	00	19/07/2024					Vincenzi Matteo	CECCARELLI A.	
	Rev.	Data / Date	Descrizione modifica / Modification description				Disegnatore	Approvato	
	Disegnatore / Designer		Approvato / Approved		Data / Date	Scala / Scale	Peso / Weight	Rif. Int.-Est. / Int.-Ext. Ref.	
	Materiale / Material		Materia Prima / Raw Material		Tolleranze gen. / Gen. tolerances		Codice Commerciale / Comm. Code		
	Rivestimento superficiale / Surface coating		Cliente / Customer		Tolleranze per lunghezze, angoli, forma e posizione / Tolerances for lengths, angles, shape and position		Codice / Code		
Denominazione / Description		CT-R290_1X350				Foglio / Sheet	Tubazioni / Pipes	EN ISO 13920 A	CT-R290_1X350
						1 di 1	Cavi / Cables		

RIVACOLD
MASTERING COLD

A3

Codice Commerciale / Comm. Code

Codice / Code

CT-R290_1X350